

Table of Contents Heavy Duty Extra Long Poly Blade
(Blade, Quadrant and A-frame)

Extra Heavy Duty Ploy Blade 10'2
Installation of light bracket 8
Shock Absorber Kit.....10

Important note:

Lift frames for this specific blade are listed below:

- Lift Frame QLII-HI-DLC-GA
- Lift Frame QLIII-HI-TILT-GA
- Lift Frame QLIV-HI-DLC-GA

For more information about lift frames, check under lift frame section.

Arctic Extra Heavy Duty Poly Blade 10'
(Blade, Quadrant & A-frame)

ARCTIC EXTRA HEAVY DUTY 10' POLY BLADE, QUADRANT, A-FRAME

Warning

Do not exceed GVWR or GAWR, including blade and ballast. The rating label is found on the driver side vehicle door corners.

Warning

Lower the blade when the vehicle is parked. Temperature changes could change hydraulic pressure, causing the blade to drop unexpectedly or damaging hydraulic components. Failure to do this can result in serious personal injury.

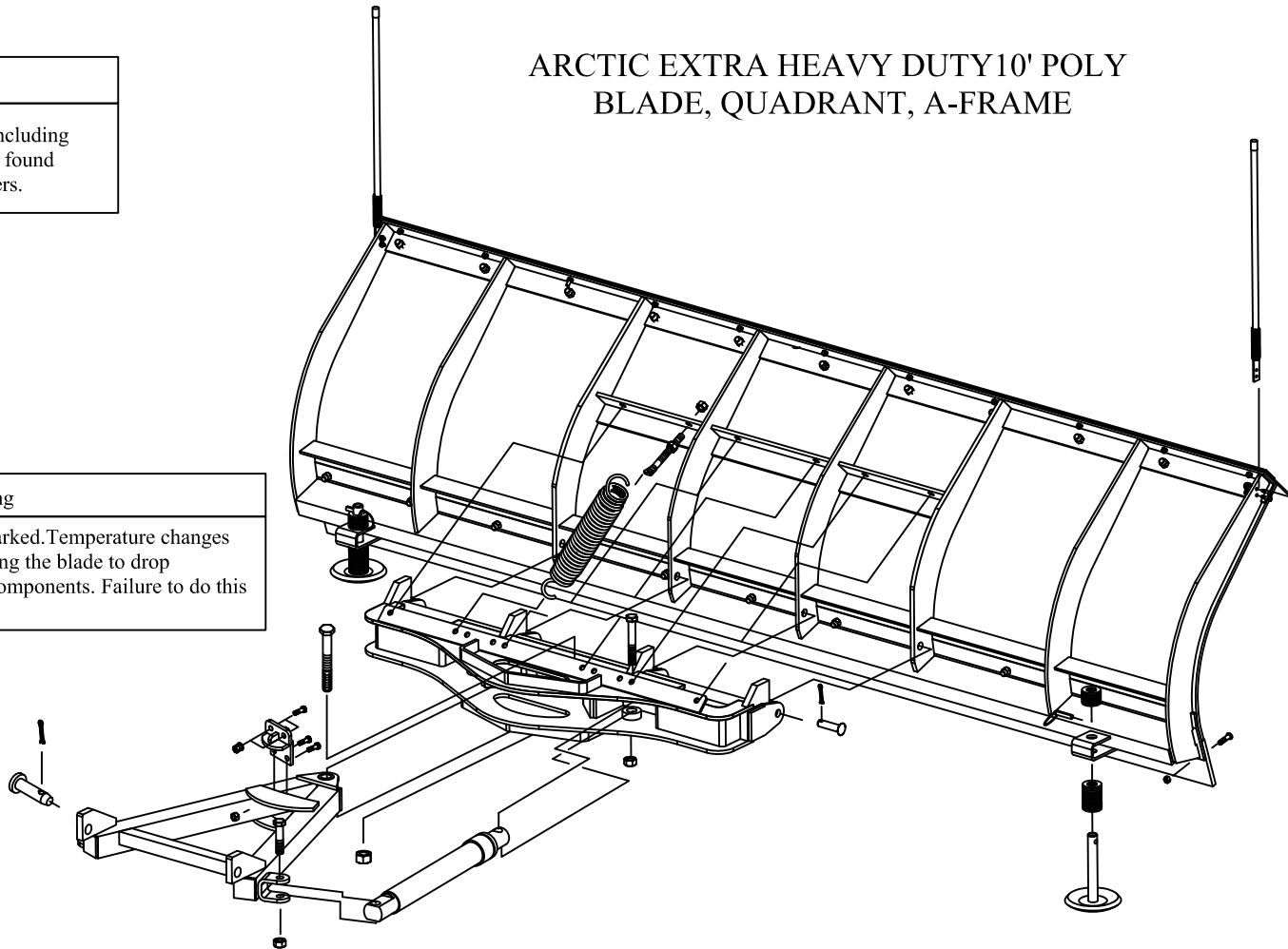

Warning

Inspect snowplow components and bolts for wear and damage when mounting or removing snowplow and before traveling.

Warning

Keep hands and feet clear of the blade, A-frame and cylinders when mounting or removing the snowplow. Moving or falling assemblies could cause personal injury. Never use a finger to check an alignment. Moving or falling assemblies could crush your finger.

Warning

Do not stand between the vehicle and the blade or within 10' of a moving blade. A moving or falling blade could cause personal injury.

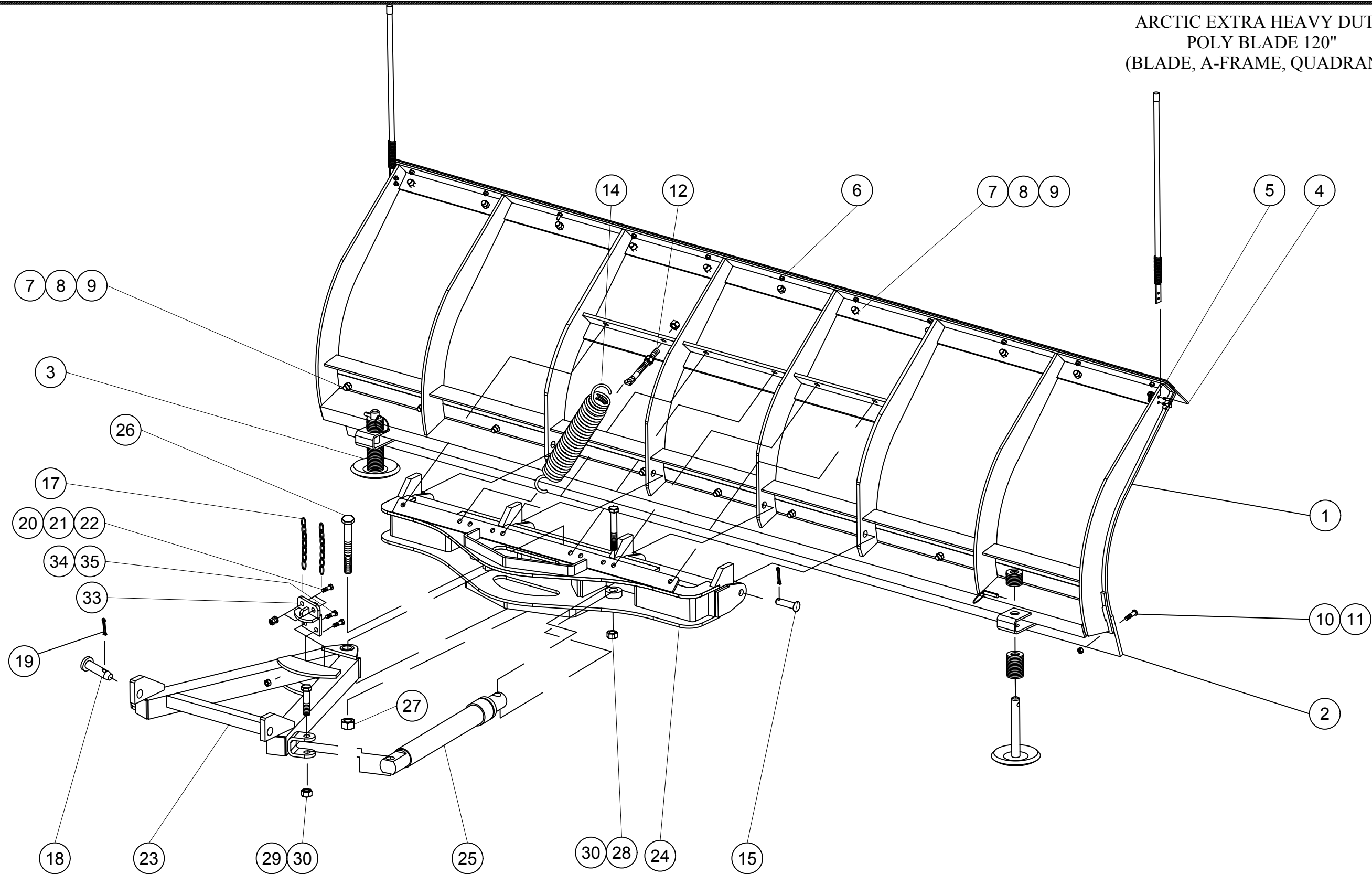

 Warning

Do not exceed GVWR or GAWR, including blade and ballast. The rating label is found on the driver side vehicle door corners.

Lower the blade when the vehicle is parked. Temperature changes could change hydraulic pressure, causing the blade to drop unexpectedly or damaging hydraulic components. Failure to do this can result in serious personal injury.

Servicing the trip springs without special tools and knowledge could result in personal injury. See Arctic authorized dealer for service.

Inspect snowplow components and bolts for wear and damage when mounting or removing snowplow and before traveling.

Keep hands and feet clear of the blade, A-frame and cylinders when mounting or removing the snowplow. Moving or falling assemblies could cause personal injury. Never use a finger to check an alignment. Moving or falling assemblies could crush your finger.

Do not stand between the vehicle and the blade or within 10' of a moving blade. A moving or falling blade could cause personal injury.

To prevent accidental movement of the blade, always turn the control OFF whenever the snowplow is not in use.

10' Poly Blade (Blade Assembly, Hardware Kit, Power Angling Assembly)					
Item	Part Number	Description	Quantity		
			52943-M-GA Blade Assembly	53027-M Hardware Kit	52944- M-GA Power Angling
1	53010-C	Poly Skin	1		
2	53030-B	Steel Cutting Edge-1/2x6x120	1		
3	50037-B-GA	Shoe Assembly	2		
4	53028-B	Poly Deflector	1		
5	53029-B-GA	Deflector Strap	1		
6	52290-M	Deflector Bolt Kit	1		
7	HH-00971-136	1/2-13x1.1/2 Carriage Bolt	22		
8	HH-00457-001	1/2 Lockwasher	22		
9	HH-00294-005	1/2-13 Hex Nut	22		
10	HH-00340-005	5/8-11 Nyl. Ins. Locknut	12		
11	HH-00971-196	5/8-11x2 Carriage Bolt	12		
12	50191-M	Eye Bolt Assembly		6	
14	50180-C	Trip Spring		6	
15	50232-M	3/4"x3" Rivet Assembly		4	
17	55018-M	Chain		2	
18	53325-A	Spreader pin		2	
19	HH-00020-164	Cotter pin		2	
20	HH-00972-090	1/2-20x1.1/2 Capscrew		2	
21	HH-00460-002	1/2-20 Hex Nut		2	
22	HH-00457-001	1/2 Lockwasher		2	
23	52945-D-GA	A-frame			1
24	52955-D-GA	Quadrant			1
25	53026-NRS	Cylinder 2" x 11.5"			2
26	HH-00972-192	1-12 5.1/2" Capscrew			1
27	HH-00540-009	1-12 Nylon Insert Locknut			1
28	HH-00972-158	3/4 X 5 1/2 NF Capscrew			2
29	HH-00972-152	3/4-16x3.1/4 Capscrew			2
30	HH-00973-007	3/4" Hex Nut Nylon Insert			4
32*	HH-00233-001	1/4-28 Grease Fitting			1
33	53395-A	Stiffener		1	
34	HH-01081-090	1/2" x 1 1/2" NC HHCS G8		2	
35	HH-01050-018	1/2" NC Hug Locknut G8		2	

* Not shown on the drawing

Installation Instructions

1. Lay blade face down on the floor. Attach the quadrant (24) to the blade by inserting the rivets (15) through the holes in the quadrant lugs and the blade ribs. Install the centre one first. Secure the rivets with the cotter pins.
2. Take an eye bolt (12) and screw one 5/8" nut all the way down the thread. Attach spring (14) to the quadrant and the eye bolt, making sure the open end of the spring faces up on the quadrant. Lift the quadrant and insert the eye bolt through the corresponding hole in the spring plate. Secure the eye bolt with another 5/8" nut. This will hold the quadrant in an upward position, and ease installation of the remaining five springs.
3. Tighten the eye bolt upper nut until the spring coils just break loose from each other. Secure eye bolts in position by tightening the lower nut against the blade spring plate.
4. Install the stiffener (33) to the A - frame and secure it using two 1/2" bolt (34) and 1/2" hug nut (35). Lift chains (17) are attached by inserting a 1/2" bolt (20) through the last link and in the hole in the stiffener (33). Tighten a 1/2" nut (21) and lock washer (22) firmly from the face side of the lifting bar.

To attach snowplow to vehicle mount, proceed as follows:

6. Position the vehicle such that the A-frame lugs and vehicle mount are in vertical alignment.
7. Hook the chain into the lift channel slot.
8. Actuate lift cylinder slowly. Blade will remain on the ground, but the A-frame will begin to rise. Continue until the A-frame lug holes align with the holes on the vehicle mount.
9. Insert the spreader pins (19) through the holes to attach the A-frame to the vehicle mount. Secure attachment by inserting cotter pins (19a) into the spreader pins.
10. With the control switch in the DOWN position, push the lift channel downward as far as possible and adjust the chain so there are two links of slack.
11. Check the cutting edge clearance. Use a combination of spacer washers until 1/2" clearance between the ground and cutting edge is achieved. Secure shoes by inserting the lynch pins into the shoe.

Installation of light bracket for ARCTIC XHD-P

A Light Bracket is used only on 10' XHD-P

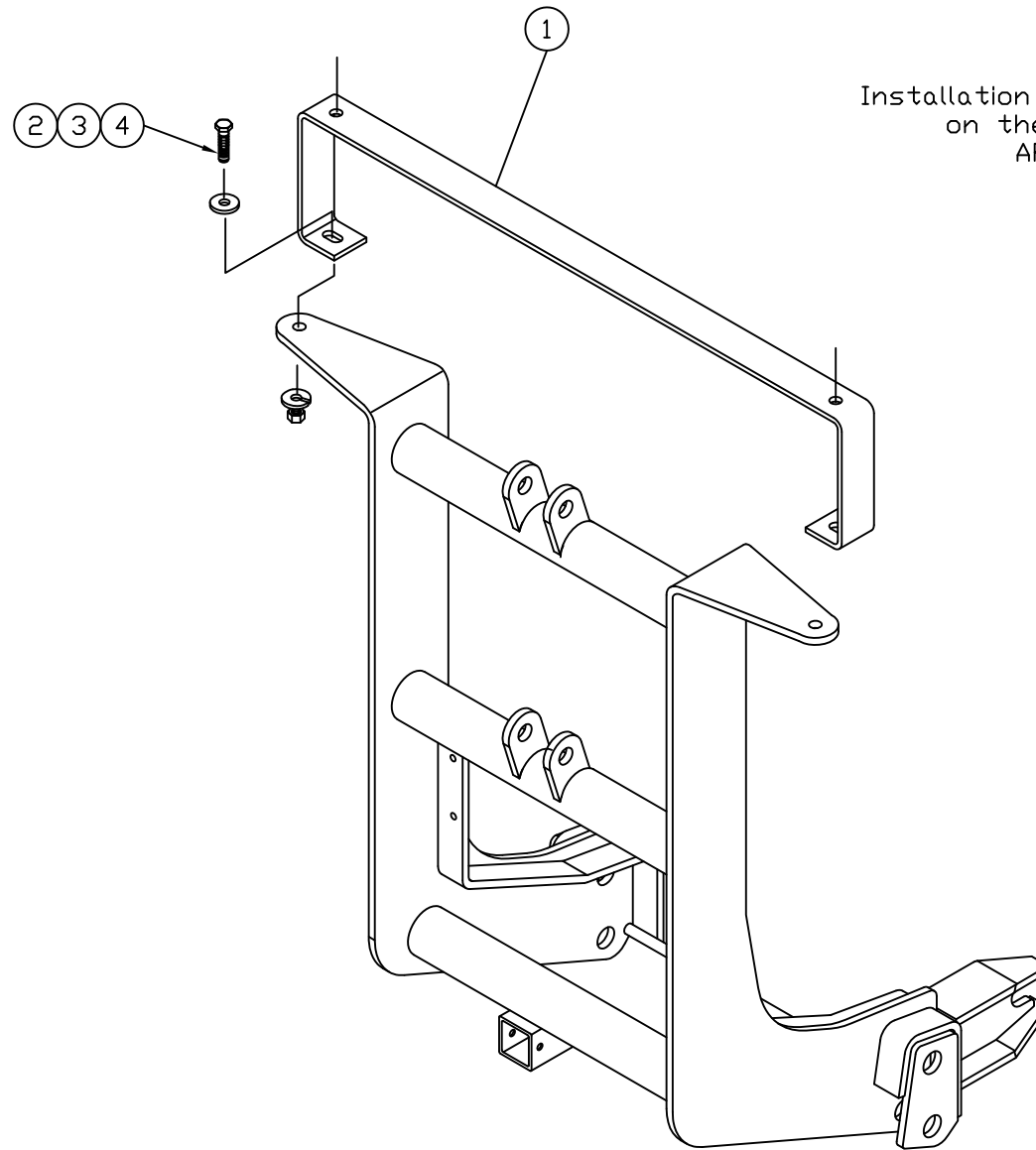

Installation of the light bracket
on the lift frame for
ARCTIC XHD-P

Installation of light bracket for ARCTIC XHD-P			
Item	Part#	Description	Quantity
1	53184-B-G	Light mounting bracket	1
2	HH-00972-090	1/2" x 1 1/2" Cap screw	2
3	HH-00540-004	1/2" Hex Nut, Nylon Insert	2
4	HH-00341-006	1/2" Flat washer	2

Arctic Equipment Manufacturing Corporation reserves the right under its product improvement policy to change construction or design details and furnish equipment when so altered without reference to illustrations or specifications used.

Shock Absorber Mounting Kit
for ARCTIC XHD-P (10' Poly Blade)

SHOCK ABSORBER FOR ARCTIC XHD-P (10' POLY)

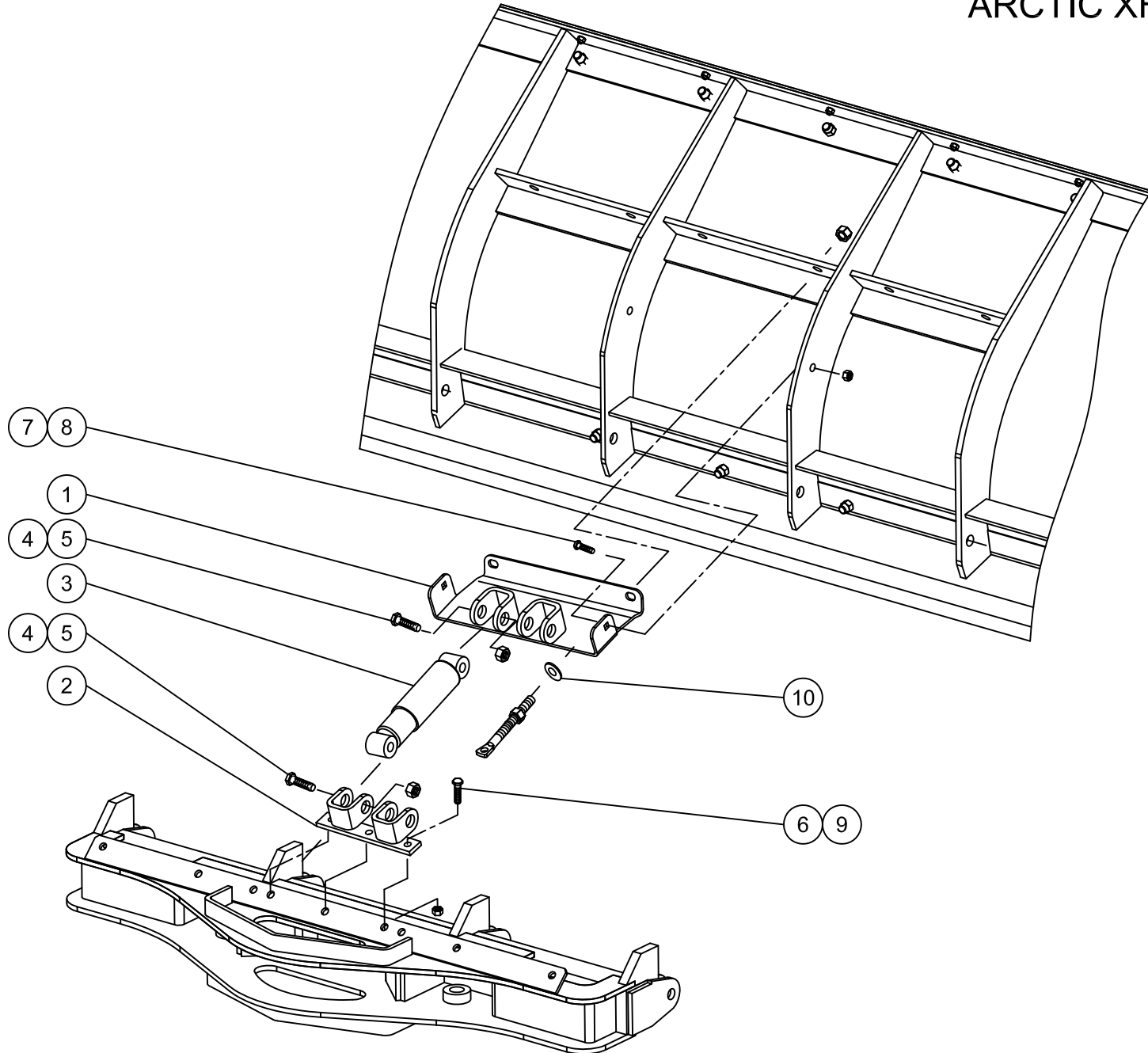

Shock Absorber Mounting Kit 53087-M-GA 10' Poly Blade			
Item	Part #	Description	Quantity
1	53088-B	Upper plate assembly	1
2	53090-A	Lower plate assembly	1
3	51984-M	Shock Absorber	2
4	HH-00972-151	3/4-16x3 Hex Head Cap Bolt	4
5	HH-00973-007	3/4-16 Nut Nylon	4
6	HH-00972-089	1/2-20x1.1/4 Hex Head Cap Bolt	3
7	HH-00971-135	1/2-13x1.1/4 Carriage Bolt	2
8	HH-00340-003	1/2" NC Nut Nylon	2
9	HH-00540-004	1/2" UNF Nut Nylon	3
10	HH-00341-008	5/8" Flat washer	2

Installation instruction:

1. Remove the two centre springs.
2. Install the upper plate assembly (1) using 1/2" carriage bolt (7) and 1/2" nut (8) to the ribs of the blade.
3. Install the lower plate assembly (2) to the quadrant using 1/2" hex head bolt (6) and nut (9).
4. Reinstall the two centre springs using 5/8" flat washer (10) under the nut of the eye bolt.
5. Install the shock absorbers (3) using 3/4" bolt (4) and 3/4" nut (5).

Arctic Equipment Manufacturing Corporation reserves the right under its product improvement policy to change construction or design details and furnish equipment when so altered without reference to illustrations or specifications used.